

MultiCube®

Suspended cubicle systems

PRODUCT TECHNICAL STATEMENT



Specifics about the system

- No fixings on the floor.
- Ideal configuration is wall to wall.
- Requires a strengthened back wall to allow for cantilevered weight of system.
- Not suitable for seismic walls.
- Our partitions are fixed to the walls at multiple locations using a full height U-channel. Please allow for a stud or full height fixings in the wall at every location where the partitions meet the wall.

Panel Information

- All Antibac panels are sourced from an ISO 9001 approved company.
- All panels are made to International Standards EN 438-2: 2005.
- No halogen, biocides, pesticides, heavy metals (e.g. lead, cadmium, chromiumVI, mercury), or plasticisers are used in the production of Antibac panels.
- Virgin raw materials are used in the manufacturer of all Antibac panels.
- All kraft paper used in the manufacture of Antibac panels is sourced from renewable forests.
- All Antibac panels are Greenguard certified and will contribute to points in the Greenstar rating system.
- All panels are anti-microbial and will actively kill 99.99% of bacteria, fungi and viruses within 24 hours.
- We offer a 10 year guarantee on panel integrity.

PANEL COLOUR OPTIONS

- MultiCube is available in:
- 12 AntiBac stock colours

- 20 AntiBac Designer colours – 12 week lead time
 - 16 Laminex colours
- For a full list go to www.resco.co.nz/colours

Aluminium information

- HEAD RAIL: Interpon powder coated 120mm x 44mm extruded aluminium 6060 alloy A-867 headrail.
- WALL CHANNELS: Interpon powder coated continuous full height 42mm x 20mm extruded aluminium 6060 alloy A-866 wall channels.

ALUMINIUM COLOUR OPTIONS

The MultiCube aluminium extrusions are available in any of the Interpon powder coating colour range or Silver Anodising. Our standard colour is Silver Pearl.

Building Code Compliance

B2.3.1 DURABILITY

Resco's products exceed requirements. Our systems are made using Compact Laminate panels that have 10 year warranty, however we expect these panels to have a serviceable life of 20+ years. (Examples: Orewa top 10 Holiday Park – over 20 years old & Waikato Stadium - over 16 years old).

E3.2, E3.3.4 INTERNAL MOISTURE

Resco's products comply with these requirements. Our products are made from

panels that have silver-ion technology. Panels actively kill up to 99% of bacteria within 2 hours for the life of the panel. The panels are waterproof and perfect for wet areas. (Tested to ISO 22196:2011, EN 438 4:2005).

GI.3.2 PERSONAL HYGIENE

Resco's products comply with these requirements. The design of Resco systems are unique, they have fewer dirt traps, improved privacy and easier to clean.

GREENSTAR V3.1 - MAT-4

Improves interior air quality by reducing VOC and Formaldehyde emissions. (Greenguard gold certification).

LIVING BUILDING CHALLENGE

Resco's Antibac panels are free of the ingredients appearing in the Red List Summary of the Living Building Challenge (Supplier declaration).

NZBC CVM2/AS2-AS7

Resco's panels are suitable for application in rooms with intermittent use. We typically propose our systems in toilet and shower blocks. (BRANZ testing FH 5110 - Group 3 rating).



RESOCO

RESOCO
ANTIBAC PANEL
Lifetime Protection

MultiCube®

Suspended cubicle systems



PRODUCT TECHNICAL STATEMENT

Hardware information

OPTION 1: RESCO ANTI-MICROBIAL HARDWARE

MATERIAL

- Diecast Zinc, Alloy ZP3.
- Brass Hinge Shaft with Nylon Inserts.
- ABS Snap on Covers.

FINISH

- High Gloss Antimicrobial Thermoset enamel Coated in grey.

MOUNTING

- Concealed Screw Fix.
- Surface Mounted.

FEATURES

- Spring assisted door opening/door closing.
- 3 x Fully Adjustable Spring Hinges to suit door.
- Can be set to Hold Open / Hold Closed.
- 1 x Matching Doorstop/Coathook.
- 1 x Easy-Glide Slide Lock for restricted hand mobility, limb loss and hygiene.
- Raised directional arrows.
- Deemed to satisfy Disability Standard AS1428.1
- Universal system provides design uniformity.

OPTION 2: RESCO BLACK HARDWARE

MATERIAL

- Diecast Zinc, Alloy ZP3.
- Brass Hinge Shaft with Nylon Inserts.
- ABS Snap on Covers.

FINISH

- Black Coated.

MOUNTING

- Concealed Screw Fix.
- Surface Mounted.

FEATURES

- Spring assisted door opening/door closing
- 3 x Fully Adjustable Spring Hinges to suit door.
- Reversible Hold Open / Hold Closed.
- 1 x Matching Doorstop/Coathook.
- 1 x Easy-Glide Slide Lock for restricted hand mobility, limb loss and hygiene.
- Raised directional arrows.
- Deemed to satisfy Disability Standard AS1428.1
- Universal system provides design uniformity.

For CAD drawings go to: www.resco.co.nz/multicube

PLAN VIEW

The MultiCube® suspended system is best in wall-to-wall configurations. Ensure that the back wall is sufficiently solid to support the Suspended MultiCube® system - this can be done by using a vertical fixing the full height of the wall.

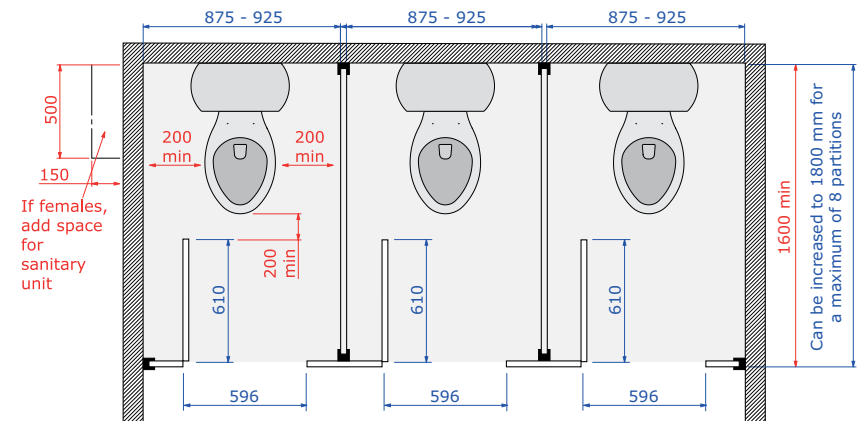

FRONT VIEW

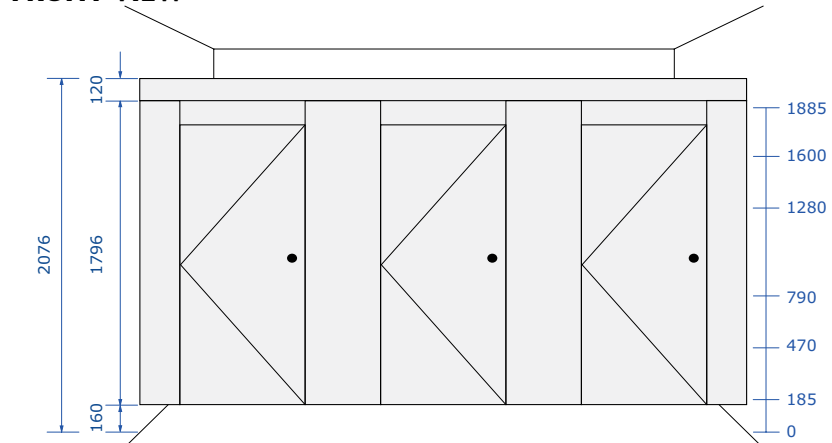

KEY	
■	NZBC G1/AS1 min Req.
■	Resco Standard

All measurements are in millimetres

Fixing points from finished floor

Dimension details

As cubicles are custom made to your measurements, depths and widths can be varied to suit, while complying with the NZ building code.

The MultiCube standard dimensions are:

- Height 2053mm with 160mm floor clearance.
- Depth 1600mm-1800mm (1900mm for accessible).
- Standard cubicles are recommended in an open-in door option.
- Standard cubicle doors are 610mm (opening is 596mm).
- Accessible cubicle doors are 810mm (opening is 796mm).
- Sliding doors are also available.

Warranty information

Our standard warranties are:

- 10 years Compact Laminate panel integrity.
- 2 years on hardware.
- 2 years on workmanship.

For further information contact Customer Services on **0800 800 950** or www.resco.co.nz.

