

Aquatic Seats

Perfect for high use areas



PRODUCT TECHNICAL STATEMENT



Specifics about the system

Bench Seats come in either

- Freestanding
- Wall mounted

Prefinished Compact laminate Bench Standard heights are:

- Free standing 475mm high
- Wall mounted - any height

Allow for vertical fixings

Customised 8mm powder coated bracket

Panel Information

- All Antibac panels are sourced from an ISO 9001 approved company.
- All panels are made to International Standards EN 438-2: 2005.
- No halogen, biocides, pesticides, heavy metals (e.g. lead, cadmium, chromiumVI, mercury), or plasticisers are used in the production of AntiBac panels.
- Virgin raw materials are used in the manufacturer of all Antibac panels.
- All kraft paper used in the manufacture of Antibac panels is sourced from renewable forests.

- All Antibac panels are Greenguard certified and will contribute to points in the Greenstar rating system.
- All panels are anti-microbial and will actively kill 99.99% of bacteria, fungi and viruses within 24 hours.
- We offer a 10 year guarantee on panel integrity.

Panel Colour Options

The Bench seating is available in:

- 12 AntiBac stock colours.
- 81 AntiBac Designer colours - 14 week lead time.
- 16 Laminex colours.

For a full list go to:

www.resco.co.nz/colours

Brackets information

- Brackets are 50x8mm formed steel powder coated Black
- Wall brackets are 380mm deep x 220mm high
- Available in freestanding or wall mounted, both fixed with Stainless bolts.

Building Code Compliance

B2.3.1 Durability

Resco's products exceed requirements. Our systems are made using Compact Laminate panels that have 10 year warranty, however we expect these panels to have a serviceable life of 20+ years. (Examples: Orewa top 10 Holiday Park - over 20 years old & Waikato Stadium - over 16 years old).

E3.2, E3.3.4 Internal Moisture

Resco's products comply with these requirements. Our products are made from panels that have silver-ion technology. Panels actively kill up to 99% of bacteria within 2 hours for the life of the panel. The panels are waterproof and perfect for wet areas. (Tested to ISO 22196:2011, EN 438 4:2005).

G1.3.2 Personal Hygiene

Resco's products comply with these requirements. The design of Resco systems are unique, they have fewer dirt traps, improved privacy and easier to clean.

RESCO

Ablution Solutions

RESCO ANTIBAC PANEL

Lifetime Protection

Aquatic Seats

Perfect for high use areas



Greenstar V3.1 - MAT-4

Improves interior air quality by reducing VOC and Formaldehyde emissions. (Greenguard gold certification).

Living Building Challenge

Resco's Antibac panels are free of the ingredients appearing in the Red List Summary of the Living Building Challenge (Supplier declaration).

NZBC CVM2/AS2-AS7

Resco's panels are suitable for application in rooms with intermittent use. We typically propose our systems in toilet and shower blocks. (BRANZ testing FH 5110 - Group 3 rating).

Dimension details

Typically seats are 450x2400 and Typically 475 off the ground

As Bench Seats are custom made to your measurements, depths and widths can be varied to suit, while complying with the NZ building code.

The standard dimensions are:

- Depth 450mm
- Width 2400mm
- Height 475mm off the floor

Warranty Information

Our standard warranties are:

- 10 years Compact Laminate panel integrity.

Wall mounted

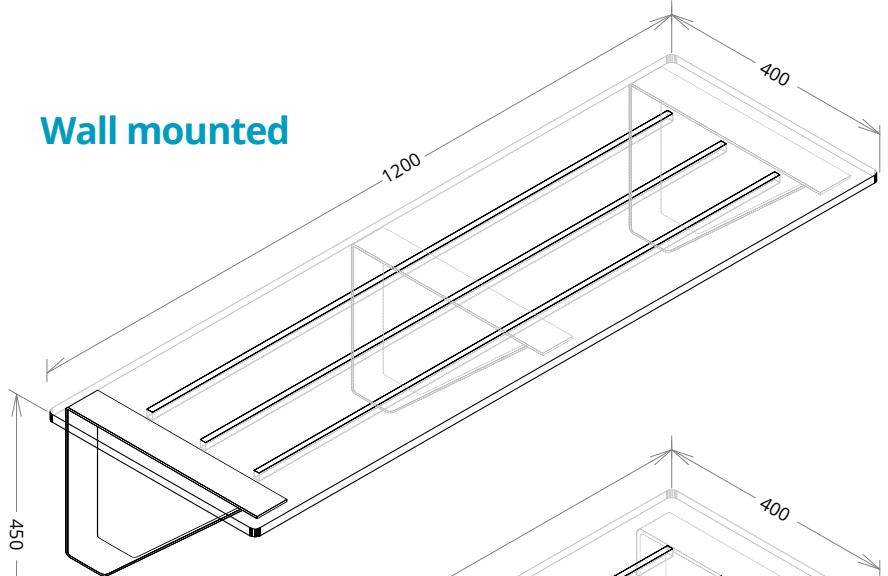

Free standing

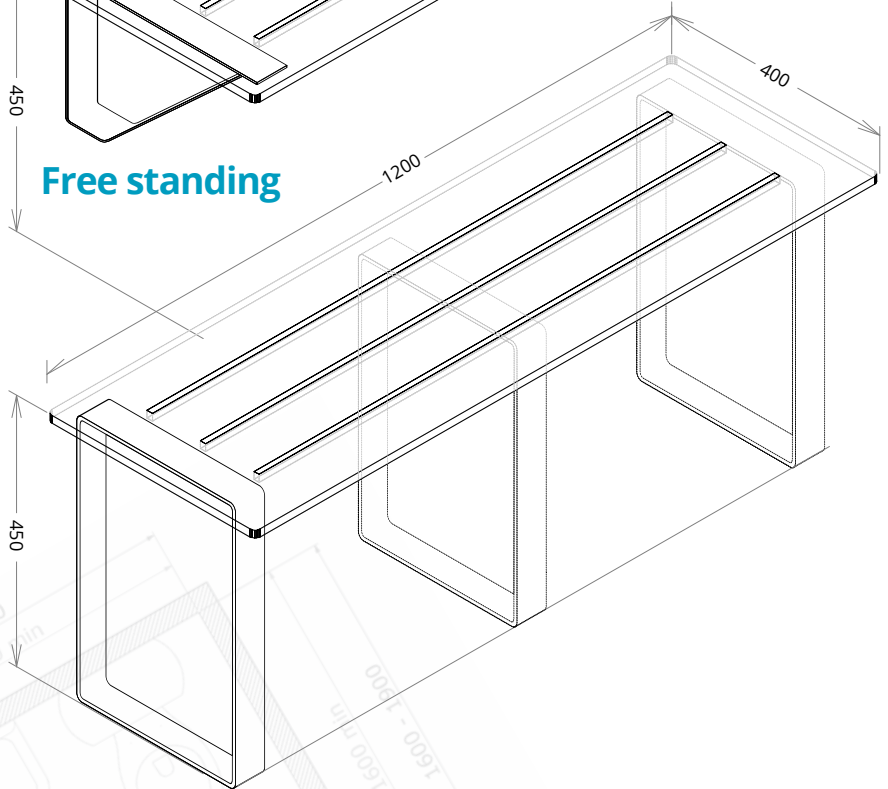

RESCO

For further information contact Customer Services on **0800 800 950** or www.resco.co.nz.