

### Surface Mount Paper Towel Dispenser and Waste Receptacle

ML707SM-MK2

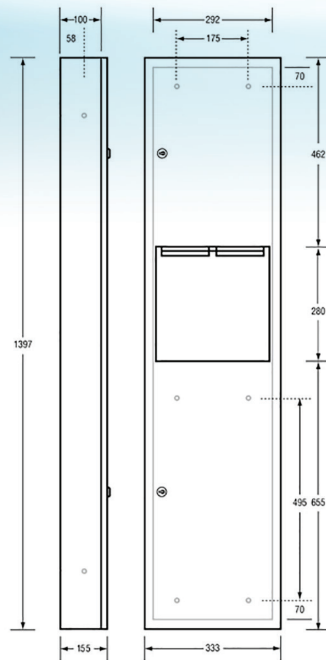

**22**  
LITRE WASTE  
CAPACITY

#### SPECIFICATIONS

Material	#304 Satin Stainless Steel
Features	Unit fitted with two tumbler locks (keyed alike) Full length piano hinge on door Seamless welds, rolled edges Larger capacity waste receptacle
Dispenser/Options	600 C-fold paper towels 800 Multi-fold paper towels
Disposal	22L Removable Stainless Steel waste container
Overall Size	333mmW x 1397mmH x 155mmD
Note	Supplied with Fitted Surround Unit is supplied with 2 keys

\*This unit is accessible compliant when installed in accordance with NZS 4121:2001-Section 10.

