

Screens

Perfect for high use areas

PRODUCT TECHNICAL STATEMENT



Specifics about the system

We have 3 different screen options:

- Privacy screens (full height) – to suit Series 5000, Series 7000 and Storm.
- Modesty screen (urinal).
- Shower screens.
 - Privacy screens for the Series 5000, Series 7000 and Storm have a post running floor to ceiling.
 - A bead clips into place for the 7000 and Storm.
 - Allow solid fixing in the ceiling where the post meets the ceiling.
 - Our screens are fixed to the walls at multiple locations using a full height U-channel. Please allow for a stud or full height fixings in the wall at every location where the partitions meet the wall.
 - Modesty screens allow fixing for 900mm bracket – 550 off the floor. Please allow for a stud or full height fixings in the wall at every location (x6) where the bracket meets the wall.
 - Shower shelf – Ideally these should be bolted through the panel onto the bracket. Ideal location is 1000mm from the floor.

Panel Information

- All Antibac panels are sourced from an ISO 9001 approved company.
- All panels are made to International Standards EN 438-2: 2005.
- No halogen, biocides, pesticides, heavy metals (e.g. lead, cadmium, chromiumVI, mercury), or plasticisers are used in the production of AntiBac panels.
- Virgin raw materials are used in the manufacturer of all Antibac panels.

- All kraft paper used in the manufacture of Antibac panels is sourced from renewable forests.
- All Antibac panels are Greenguard certified and will contribute to points in the Greenstar rating system.
- All panels are anti-microbial and will actively kill 99.99% of bacteria, fungi and viruses within 24 hours.
- We offer a 10 year guarantee on panel integrity.

PANEL COLOUR OPTIONS

Our Screens are available in:

- 12 AntiBac stock colours.
- 20 AntiBac Designer colours – 12 week lead time.
- 16 Laminex colours.

For a full list go to www.resco.co.nz/colours

Aluminium information

- WALL CHANNELS: Interpon powder coated continuous full height 42mm x 20mm extruded aluminium 6060 alloy A-866 wall channels.
- FULL SCREEN 5000 POST: Interpon powder coated 50mm extruded aluminium 6060 alloy full length tubular.
- FULL SCREEN 7000 POST: A-862 full stiles with clashing rebated door stops lined with wool pile. These also act as the pedestal with the top of post to be screw fixed to ceiling and fixed to floor with the bracket. With A865 Bead – that clips into place.
- FULL SCREEN STORM POST: A-855 full stiles with clashing rebated door stops lined with wool pile. These also act as the pedestal with the top of post to be screw fixed to ceiling and fixed to floor with the pin and bracket. With A852 Bead – that clips into place.

- MODESTY SCREEN BRACKET: Stainless steel 80mm x 900mm.

ALUMINIUM COLOUR OPTIONS

The Screen aluminium extrusions are available in any of the Interpon powder coating colour range or Silver Anodising. Our standard colour is Silver Pearl..

Building Code Compliance

B2.3.1 DURABILITY

Resco's products exceed requirements. Our systems are made using Compact Laminate panels that have 10 year warranty, however we expect these panels to have a serviceable life of 20+ years. (Examples: Orewa top 10 Holiday Park – over 20 years old & Waikato Stadium - over 16 years old).

E3.2, E3.3.4 INTERNAL MOISTURE

Resco's products comply with these requirements. Our products are made from panels that have silver-ion technology. Panels actively kill up to 99% of bacteria within 2 hours for the life of the panel. The panels are waterproof and perfect for wet areas. (Tested to ISO 22196:2011, EN 438 4:2005).

G1.3.2 PERSONAL HYGIENE

Resco's products comply with these requirements. The design of Resco systems are unique, they have fewer dirt traps, improved privacy and easier to clean.

BUILDING CODE COMPLIANCE CONTINUED NEXT PAGE

RESCO

RESCO
ANTIBAC PANEL
Lifetime Protection

Screens

Perfect for high use areas



PRODUCT TECHNICAL STATEMENT

For CAD drawings go to: www.resco.co.nz/screens

FULL SCREEN FS-1800

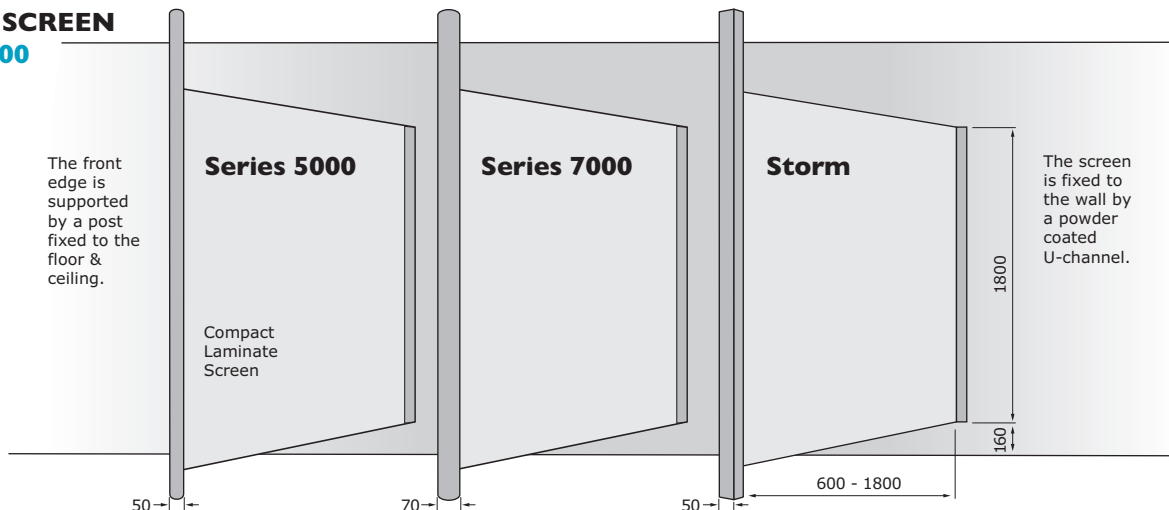

SHOWER SCREEN SS-1750

The shower screen can be either a Compact Laminate panel or curtain.

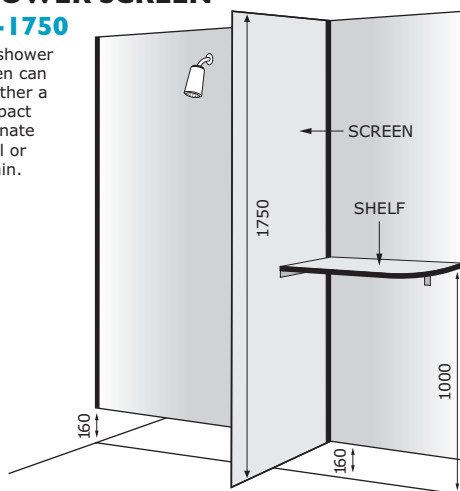

SHOWER SHELF SF-900p

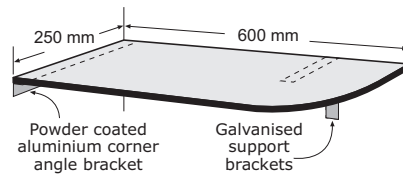

SF-900c

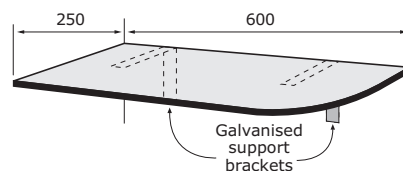

MODESTY SCREEN MS-900

The screen is fixed to the wall by a robust 75mm half-rounded aluminium extrusion finished in satin anodising.

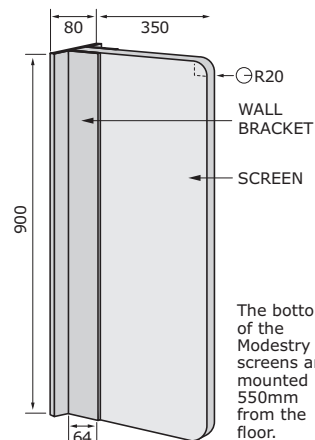

All measurements are in millimetres.

BUILDING CODE COMPLIANCE CONTINUED

GREENSTAR V3.1 - MAT-4

Improves interior air quality by reducing VOC and Formaldehyde emissions. (Greenguard gold certification).

LIVING BUILDING CHALLENGE

Resco's Antibac panels are free of the ingredients appearing in the Red List Summary of the Living Building Challenge (Supplier declaration).

NZBC CVM2/AS2-AS7

Resco's panels are suitable for application in rooms with intermittent use. We typically propose our systems in toilet and shower blocks. (BRANZ testing FH 5110 - Group 3 rating).

Hardware information

- SHOWER SHELF BRACKET: Galvanised Bowmac B565 bracket.

Dimension details

Full privacy screens are typically 160mm off the floor to suit the cubicles, at a 1800mm height totalling 1960mm off the floor. The depth can be anywhere from 100mm to 1900mm.

Warranty information

Our standard warranties are:

- 10 years Compact Laminate panel integrity.
- 2 years on hardware.
- 2 years on workmanship.



For further information contact Customer Services on **0800 800 950** or www.resco.co.nz.