

Product: Resco StormCube	Product Code: StormCubeWW
Installation Guide Wall to wall version. April 2017	

RESCO

*Storm***Cube**

Advanced cubicle systems

Step-by-step Installation Guide

WALL TO WALL VERSION

April 2017

IMPORTANT

SAFE PANEL HANDLING INSTRUCTIONS



Although Compact Laminate panels are tough and durable, they must be treated with care. Panels can be damaged if not stored or handled properly during assembly.

Store inside and keep in original packaging until needed.

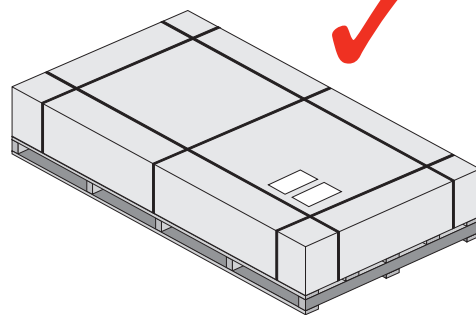

Use caution, machined edges may be razor sharp!

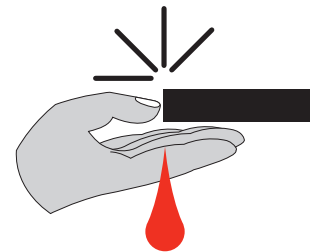

DO NOT store in sun or rain, or at high temperatures.

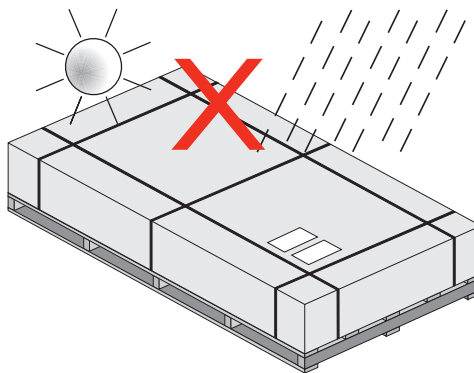

DO NOT slide panels - LIFT them!

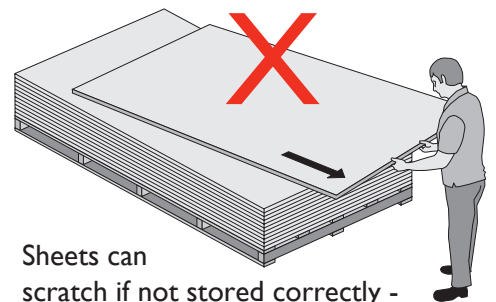

Sheets can scratch if not stored correctly - ensure free of dust and debris.

DO NOT walk-over.

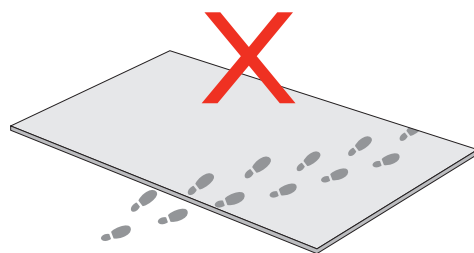

2 MAN LIFT.

Use suction lifting aids if available.

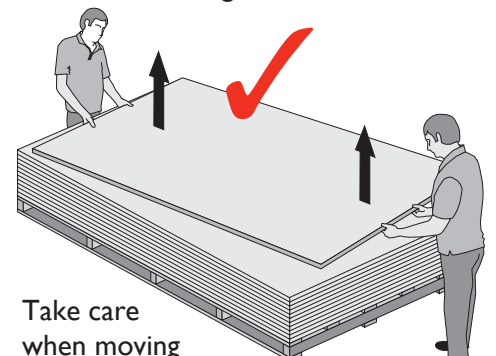

Take care when moving panels they can be damaged if not handled correctly.

IMPORTANT

CLEANING & MAINTENANCE OF COMPACT LAMINATE

Compact laminate is engineered to last for many years. We provide a 10 year guarantee on panel integrity.

The non-porous surface is easy to clean. The decorative surface and resin core of Compact Laminate is impervious and resistant to most commonly used cleaning agents and disinfectants.



Recommended cleaning agents

Surfaces can be easily cleaned with a dry or damp cloth and if necessary a mild household cleaner.

- **General cleaning:** All-purpose cleaner (e.g. Ajax Spray & Wipe), household cleaners, water or soap are recommended.
It is resistant to everyday wear and tear but needs some attention for harsh conditions and staining.
- **Spray paint:** Turpentine or SPC 801
- **Permanent marker:** Methylated spirits or SPC 801

Never use any of the following on the panels, aluminium or hardware:

- Do not use abrasive or polishing materials. Abrasive cleaners such as Jif Cream Cleanser, Ajax (powder or liquid), Chemco, Brasso, Mr. Muscle oven cleaner or Scrub free.
- Scourer pads, Wire wool or Sandpaper.
- High pressure water cleaning or steam cleaning of panels is not recommended.
- Neat Janola or other equivalent brands of bleaches.
- Any product containing strong mineral acid such as sulphuric acid, Battery acid, hydrochloric acid, nitric acid or phosphoric acid. Commercial toilet cleaners, grout removers, descalants, rust removers, bleach, etc.
- Care must be taken where cleaning agents or solvents are highly acidic or alkaline as these may permanently damage the surface.

Ongoing Maintenance:

- The use of CRC or equivalent on hinges and indicator bolts is recommended at least once every 3 months (sooner for challenging environments).
- An occasional re-finish of the exposed edges with an “off the shelf” wood-polish will rejuvenate the original polished seen edges.
- Any chemicals should be washed off so that they don’t keep working.
- Finger prints and other such surface marks can be neutralised with a silicone spray and a micro-fibre cloth.

See our Web site:

www.resco.co.nz/product/multicom - Cleaning instructions

For removal of graffiti – Please call our customer service team **0800 800 950**

Step-by-step Installation Guide

Follow the installation instructions and reference numbered steps on the illustrations.

IMPORTANT NOTES

- When screwing into compact you must pre-drill.
- Use low setting on your drills when screw fixing into Compact Laminate. Compact Laminate can break screws or damage the head if your drill is too powerful.
- Don't use hammer drills when installing into Compact Laminate.
- Compact Laminate and Aluminium can damage if not stored or treated properly – take care when you are moving sheets. Larger sheets require 2-man lift.
- The system will be packed so division panels are at the top and the doors are at the bottom.
- Use Diamond tip drill bits for drilling into tiles.
- Oversize Fascias – rivet infill in the middle (of the 2 other rivets on the other side) of the pedestal at the opposite side to ensure that the infill can't be moved.

Sit in place and ensure that all the doors are perfect before final rivet. Therefore you can adjust. Ensure plumb both ways.

Tools needed

- Level
- String line
- Chalk line
- Stool or small step ladder
- Timber blocks (155 mm)
- Timber wedges
- Rivet tool
- 3.5 mm drill bit
- 5 mm Masonry bit
- No. 1 Square drive
- No. 2 Pozi-drive
- Drop saw
- Nylon hammer
- Circular saw

StormCube WALL TO WALL VERSION

Step 1

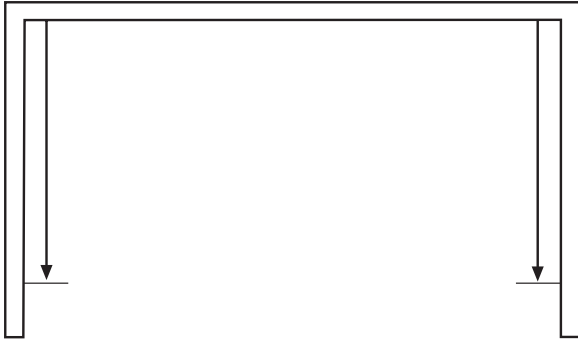

From the 'Resco Shop Drawings', mark the distance from the back wall to the front of the cubicles.

Step 2

From the 'Resco Shop Drawings', mark Datum on relevant walls.

Note: on our proprietary system the Datum is normally 1960mm.

Ensure that the lowest point in the floor is used for the Datum line otherwise posts could be too long, the system could be on an angle, or the Headrail height could be too low.

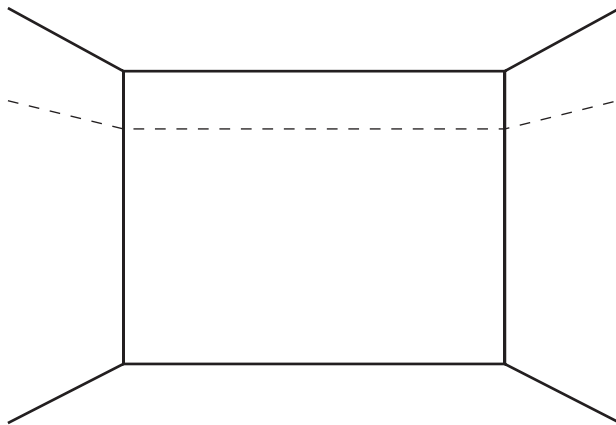

Step 3

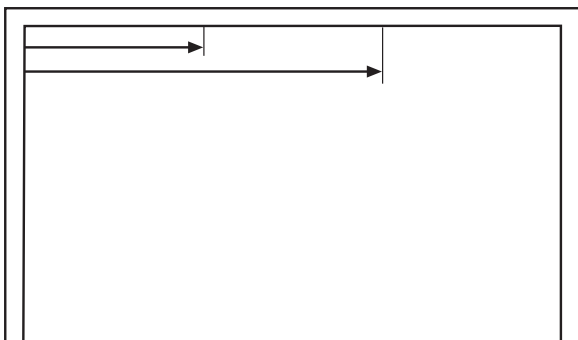

From the 'Resco Shop Drawings', mark the division centres on the back wall.

- a. Check location of toilets and ensure centered (these are sometimes fitted differently to the plans).

Step 4

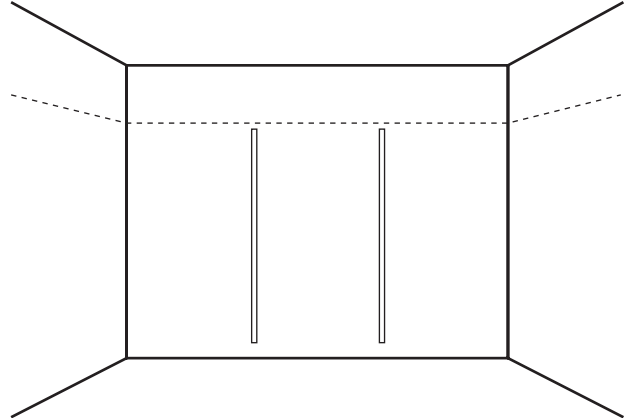

Fix back U-Channels (1748mm) centered on your marks, 52mm below the Datum line.

- a. The U-Channels are predrilled. Ensure screws go into wall frame.

Use (A) 8GA x 32 screws (with a (F) plastic anchor if required).

Step 5

Mark centre location of 1/2 stile

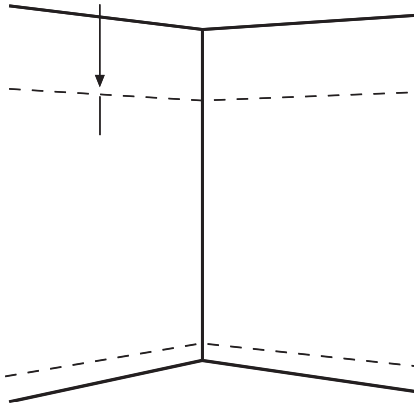

Mark centre location of 1/2 Stile using shop drawings

- Place top of 1/2 Stile on datum line centred at this mark and plumb.
- Screw fix 1/2 stile to wall through pre-drilled holes on 1/2 stile

Use (C) 8GA x 50 screws

Note: If 1/2 Stiles have hinges, the hinges will be fitted on the 1/2 Stile without the centre screw. Place top of 1/2 Stile on the datum line, plumb and screw fix to wall through all 3 centre hinge holes.

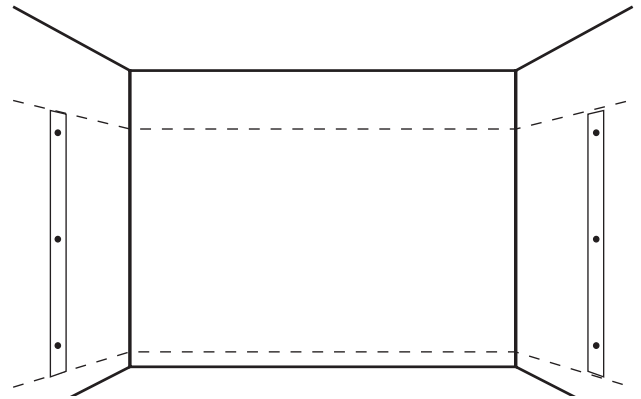
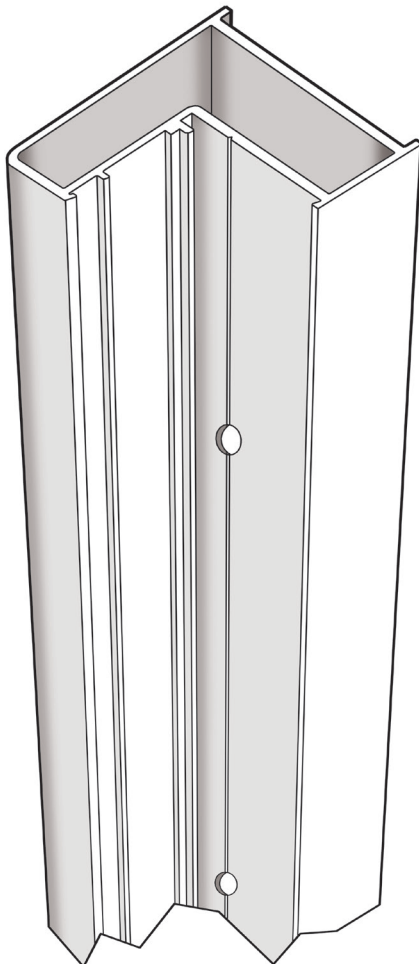

Step 6

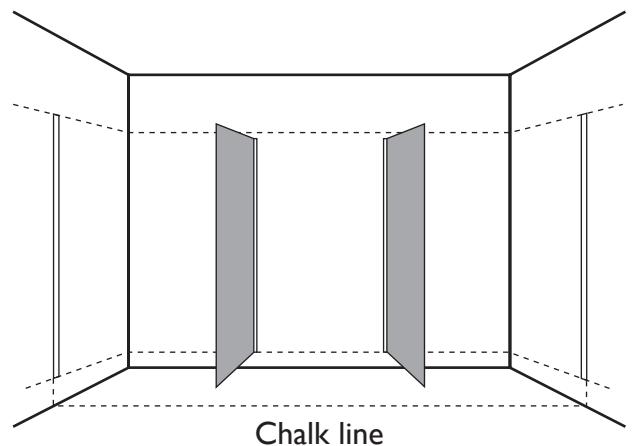

Mark a 'front face' chalk line on the floor.

- Chalk line from the center of the 'side wall 1/2 Stiles'.
- Place division panels into the rear U-channels with the adjustable feet underneath. Adjust them so they are level.
- Adjust division panels so they are -15mm from the chalk line and aligned with the top of the U-Channel then fix.

Rivet through one side of U-Channel, Use 3.5mm Drill but with a (D) Stainless steel pop Rivets.

Note: Sometimes the back wall is not straight. This can be ok as you can either trim the division panels as required, or adjust the front face. Just ensure you remark the chalk line and that it's straight, fits and looks good.

Step 7

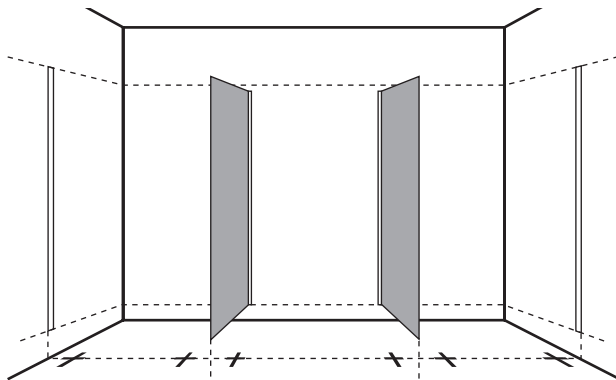

From the Resco Shop drawings, mark the full stile centres on the chalk line.

Note: make sure to leave enough pencil mark along the chalk line to be seen from under the full stile footprint. This is so you can ensure the panels will be centred.

Step 8

Floor mounted bracket positions are located by placing a small off cut of the Full stile over the full stile centres you marked in the previous step. Ensure you have the correct orientation, by checking the Resco Shop Drawings to ensure the full stile is orientated correctly. Then place the floor mounted bracket into position and fix in place.

Use 5mm Masonry drill bit in concrete floor and 3.5mm drill bit in wood floor or a diamond drill bit for tiles.

Place (F) plastic anchor in hole.

Secure floor block, using (A) 8gax32 screws.

Step 9

Full-Stiles

Use a laser level (or string line) between the tops of the 1/2 Stiles.

- a. Trim all full Stiles to height, by putting each full Stile upside down over the appropriate floor mount, mark and then trim.

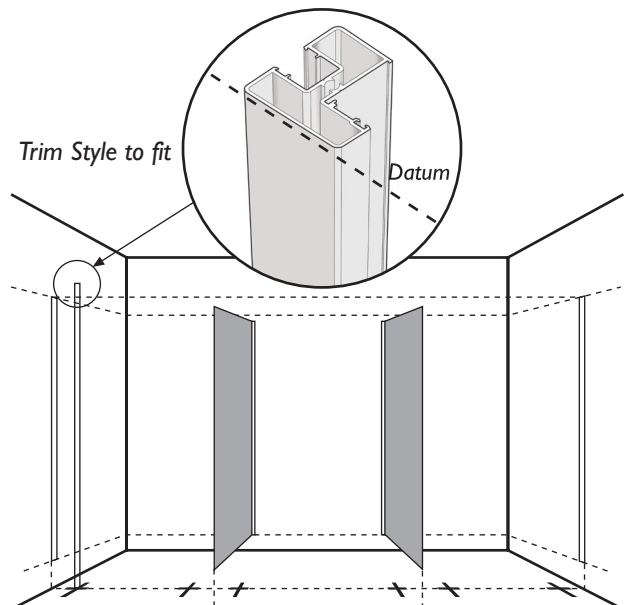

Floor mount brackets located in position. (Indicative only. Not to scale.)

StormCube WALL TO WALL VERSION

Step 10

Place left hand end Fascia in position and Screw fix in place, ensuring you leave a 2-3mm gap for the Aluminium bead to slot in.

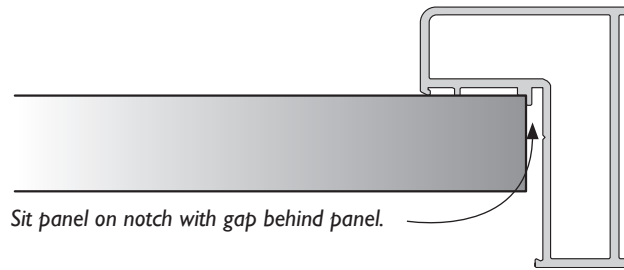

Use (A) 8GA x 25 mm screws.

Clip ½ Stile bead in place.

Use Silicone to hold in place.

Place the right hand side end fascia into position onto blocks – just hold it in position for now.

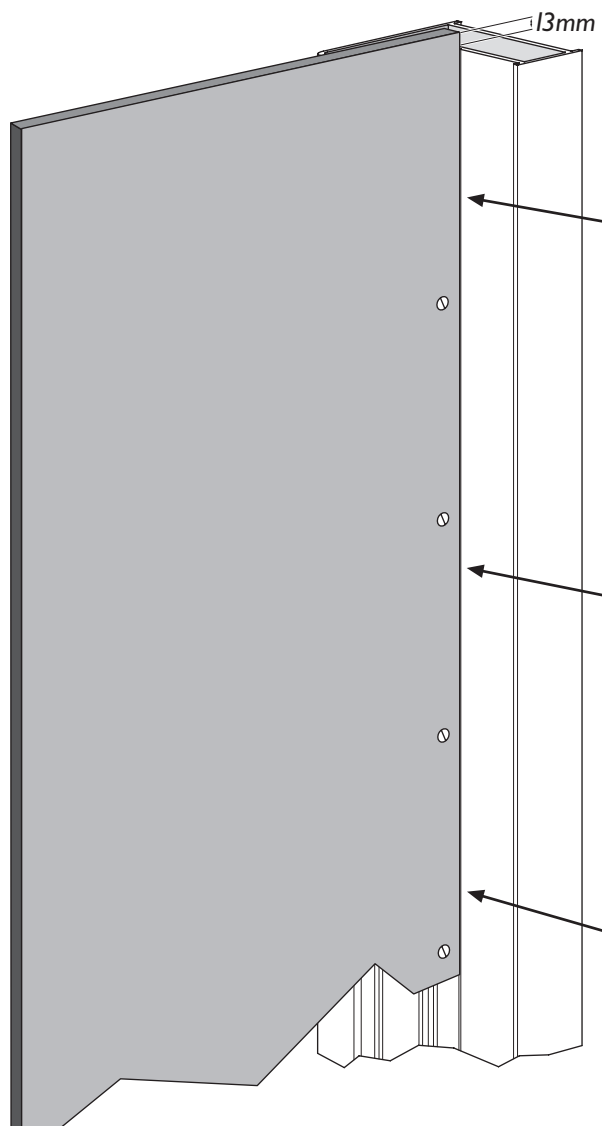

Push aluminium bead to click in place.
(use additional polymer as required).

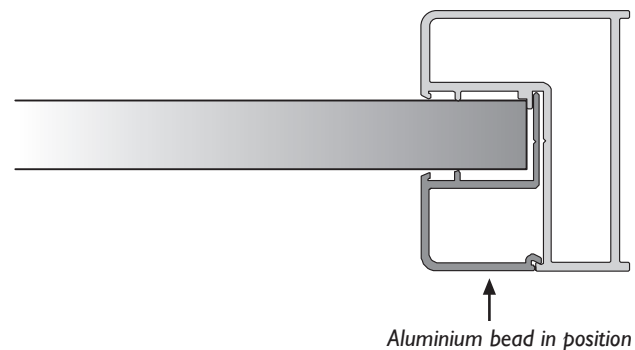
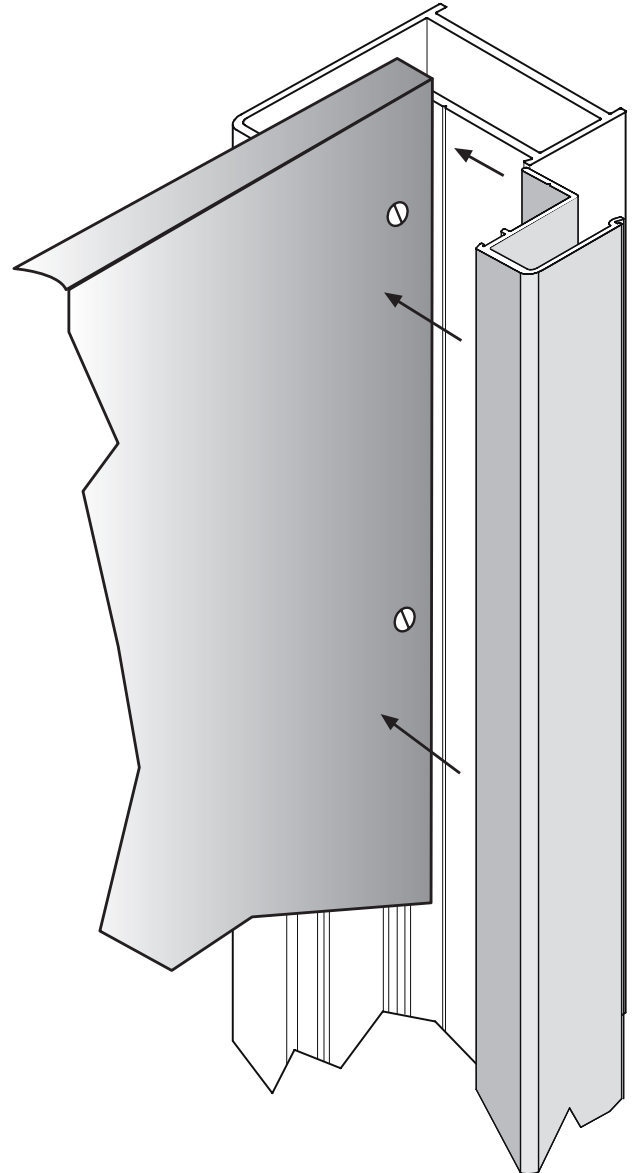

RESCO

StormCube WALL TO WALL VERSION

Step 11

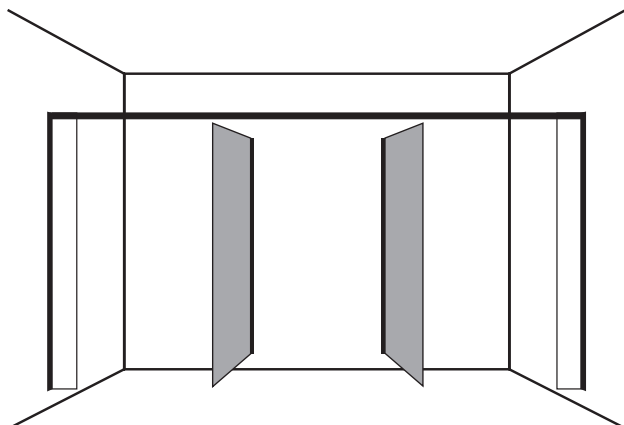

Headrail - Sit in place. This may require trimming as Headrails are supplied oversize. As Headrails are predrilled, make sure any trimming is done at the correct end - there will be a sticker to indicate which end.

- Ensure the Headrail is touching the walls perfectly.
- Fix headrail to side ½ stiles, with screws through the top, 20mm from each end.

Ensure you drill holes straight so you don't drill through the panel.

Use 3.5mm drill bit with (D) Stainless Steel Pop Rivets.

Step 12

Place the locating pin into the hole, place the template of the stile over the pin, drill and fix down compact block.

Place the first Full-Stile over the appropriate floor mount.

Check the Resco shop drawings to ensure that the full stile is orientated correctly.

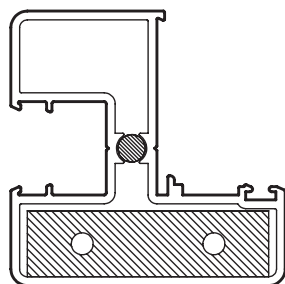

- Make sure it sits on the floor with the stile mounted over the floor bracket. (Not to scale).

chalk line running through the centre of the stile.

- Fix the top (loosely) through the Headrail's predrilled holes into the Full Stile.

Use 14g x 65 pan head screws.

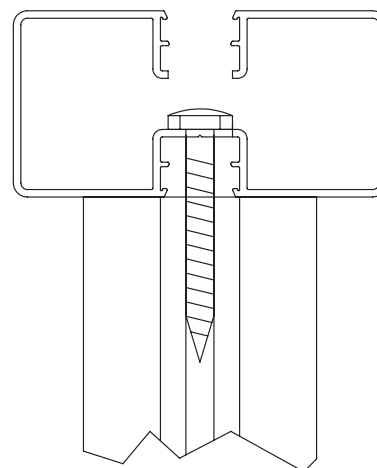
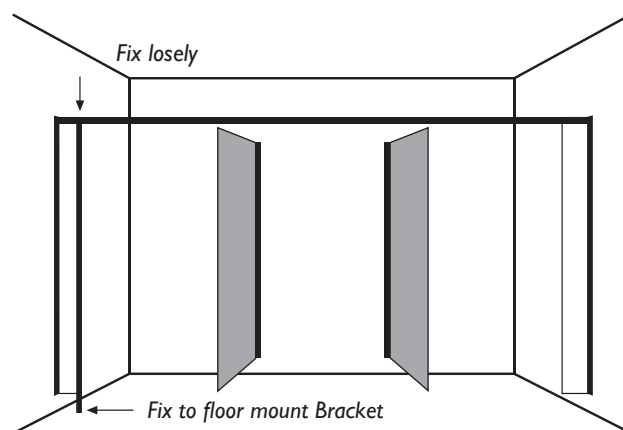

Headrail connecting into the Full Stile. (Not to scale).

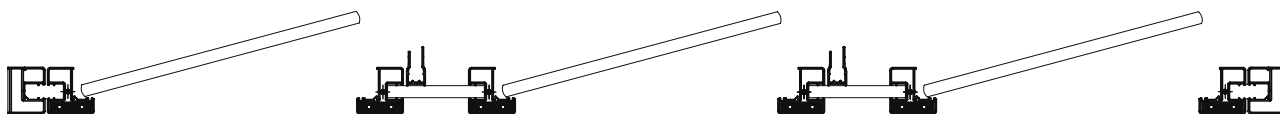

Full Stiles located in position over the floor mount brackets. (Indicative only. Not to scale.)

Step 13

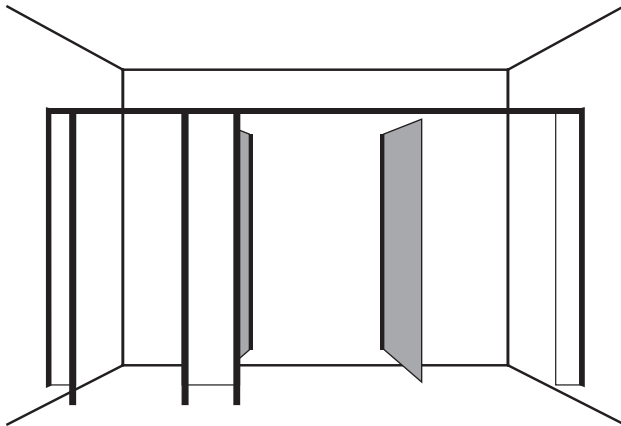

Place the next full stile into position and fix in place. Check the 'Resco shop drawings' to ensure that the full stile is orientated correctly.

Insert appropriate Fascia and align U-Channel with corresponding division panel.

Apply 4 blobs of silicon in Stile pocket to prevent panel rattling in the future.

- Move Fascia (and division panel) sideways across into fixed Stile pocket.
 - Ensure pushed hard into Headrail and put block under Fascia to maintain height.
 - Slip next Full-Stile onto the other side of the Fascia.
- Check the Resco shop drawings to ensure that the full stile is orientated correctly.
- Move the top-end in to position above the screw.
 - Fix loosely for now to Headrail.

Use 14g x 65 pan head screws.

Step 14

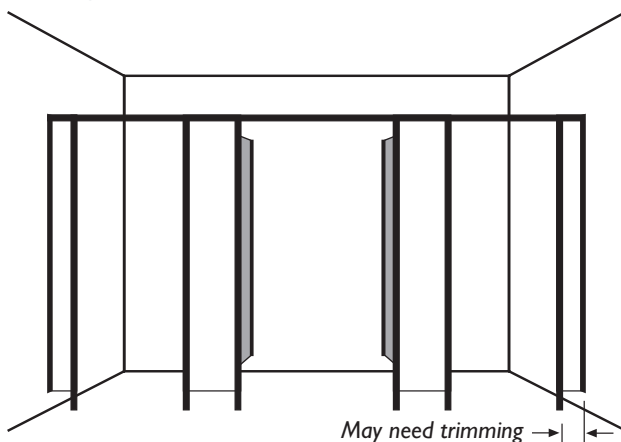

Repeat for the remaining Stiles and Fascias. Check the last Fascia before fixing as it may need trimming.

To trim use a tungsten tipped blade.

Tighten up all of the Headrail screws.

Step 15

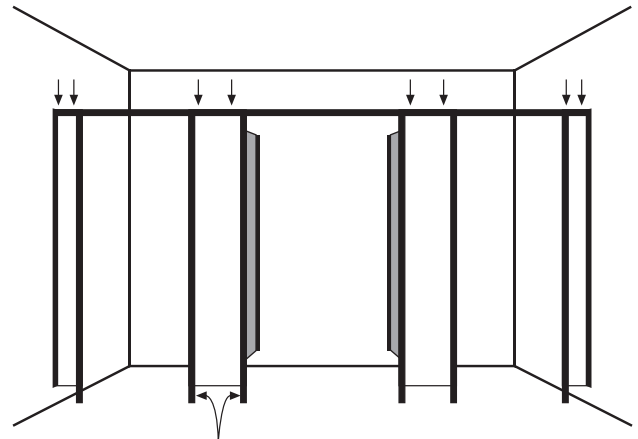

Insert pocket infills

Fix Fascia panels in place, screw fix Headrail into the top of the full stiles.

Use a 3.5mm drill and fix with (E) 8GA x 20 counter sunk screws.

Place Full-Stile pocket-infills to fill pockets between the finished floor and the bottom of the panels. These may need trimming if Stiles have been shortened.

Clip into place.

Step 16

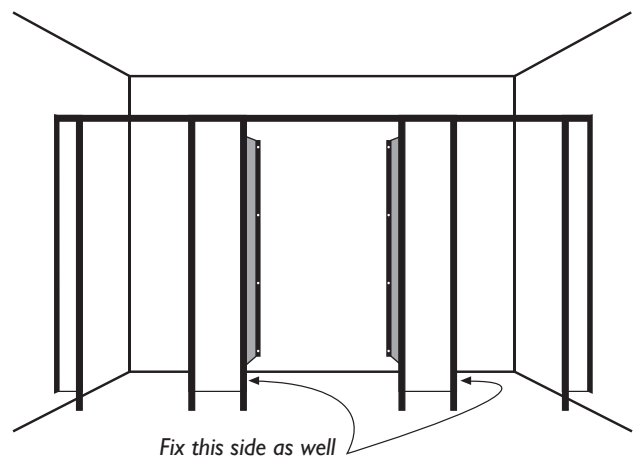

Fix this side as well

Fix division panels

- Ensure all division panels line up with the bottom of each U-Channel.
- Drill 4 x holes on one side of each U-Channel.

Use 3.5mm drill bit with (D) Stainless Steel Pop Rivets 30mm and 600mm from the top and the same from the bottom.

Step 17 Hang doors

Lining up the hinges attached to each stile with the predrilled holes on the doors, hang the doors.

Use the supplied (B) 8GA x 12 screws.

Step 18 Fit hardware

COAT HOOK

Line up the coat hook with the pre-drilled holes in the doors and screw on.

Use (B) 8GA x 12 screws.

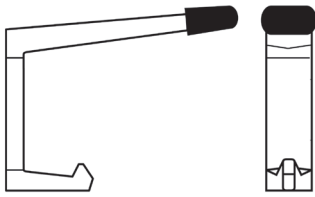

Fix the indicator bolt in the pre-drilled position.

INDICATOR BOLT

Step 01 - Front Component Coat Hook

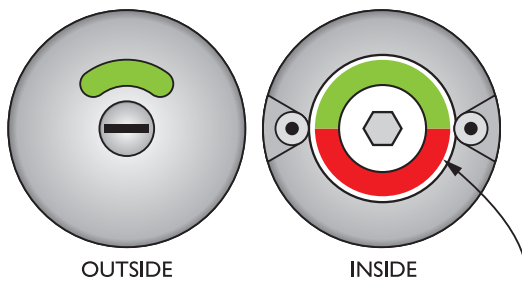

Insert the green and red plate into the inside of the front component of the indicator bolt.

Step 02 - Diamond Back Plate

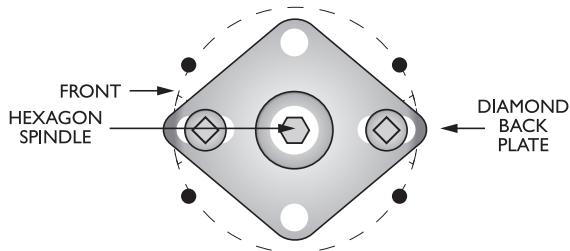

Fix the front part of the indicator bolt to the outside of the door using the diamond back plate on the inside of the door.

Use 2 x 8g x 1/2 screws.

Insert the hexagon shaped spindle into the front plate from the inside.

Check the indicator is green and then check the bolt lock is in the Open position.

Step 03 - Inside Bolt

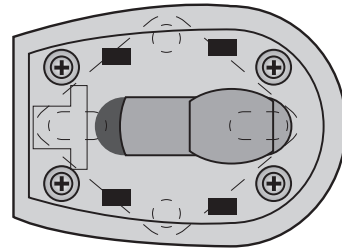

Screw the inside bolt component onto the inside of the door over the Diamond Back Plate.

Use 4 x 6g x 20mm screws.

Check that the lock can slide back and forth smoothly. In case it jams it means that the hexagon spindle is not perfectly perpendicular. You will need to gently slide the front of the indicator left/right.

Step 04 - Coverplate, Knob & Keeper

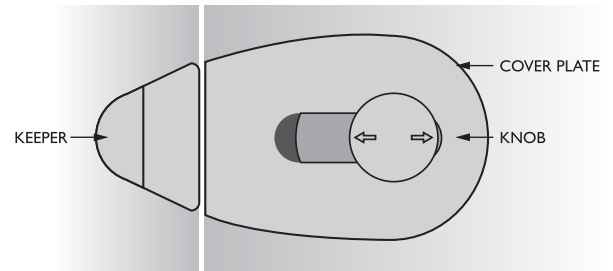

Then clip on the cover plate. Push on the knob and tighten the grub screws with the allen key supplied. A keeper will already be installed on the Stile.

Step 19 Clean Panels

Clean all components, including pencil marks on the floor and walls.

Sweep the floor and remove rubbish.

Wipe down with soapy water.

RESCO

Resco Limited.
12 Kahu Crescent
Te Rapa Park, Hamilton 3200. New Zealand
Phone: 0800 800 950, +64 850 1025
Fax: +64 7 850 1026
(www.resco.co.nz)

©Resco April 2017

RESCO