

Product: Multicom	Product Code: M-Com
Multicom Installation Guide 3 x Options version. November 2015	

RESCO

MultiCom[®]

Advanced wall panelling



Step-by-step Installation Guide

November 2015

Including 3 installation options:

- Option 1. Direct fixing onto timber frames (Dry areas)**
- Option 2. Timber framed walls (Wet areas)**
- Option 3. Solid flat surface walls (Wet areas)**

Resco Limited.
12 Kahu Crescent
Te Rapa Park, Hamilton 3200.
New Zealand
Phone: 0800 800 950, +64 850 1025
Fax: +64 7 850 1026
(www.resco.co.nz)

IMPORTANT

SAFE PANEL HANDLING INSTRUCTIONS



Although Compact Laminate panels are tough and durable, they must be treated with care. Panels can be damaged if not stored or handled properly during assembly.

Store inside and keep in original packaging until needed.

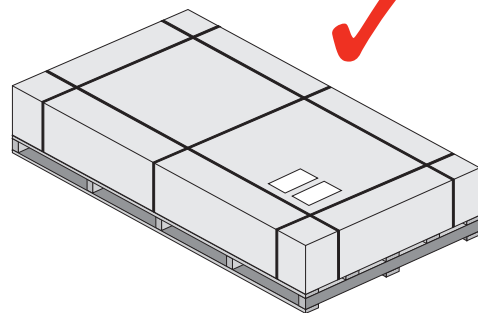

Use caution, machined edges may be razor sharp!

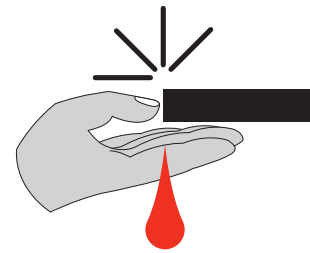

DO NOT store in sun or rain, or at high temperatures.

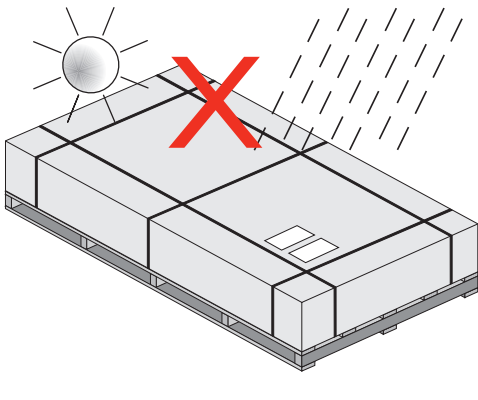

DO NOT slide panels - LIFT them!

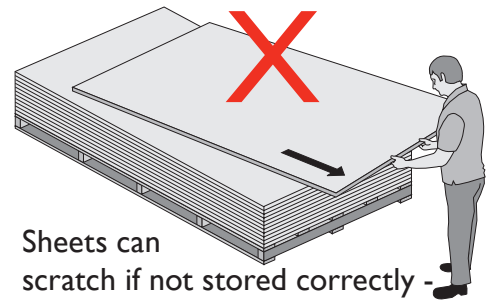

Sheets can scratch if not stored correctly - ensure free of dust and debris.

2 MAN LIFT.

Use suction lifting aids if available.

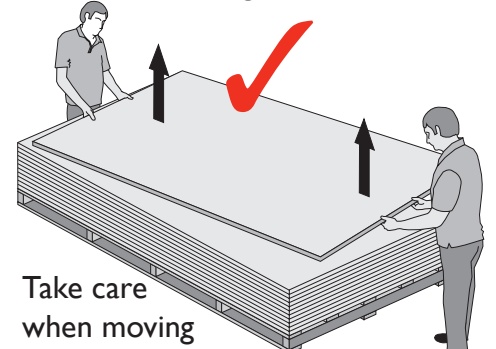

Take care when moving panels they can be damaged if not handled correctly.

DO NOT walk-over.

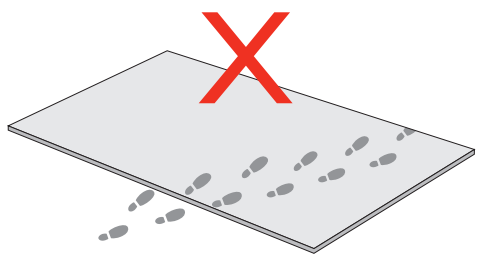

IMPORTANT

CLEANING & MAINTENANCE OF COMPACT LAMINATE

Compact laminate is engineered to last for many years. We provide a 10 year guarantee on panel integrity.

The non-porous surface is easy to clean. The decorative surface and resin core of Compact Laminate is impervious and resistant to most commonly used cleaning agents and disinfectants.



Recommended cleaning agents

Surfaces can be easily cleaned with a dry or damp cloth and if necessary a mild household cleaner.

- **General cleaning:** All-purpose cleaner (e.g. Ajax Spray & Wipe), household cleaners, water or soap are recommended.

It is resistant to everyday wear and tear but needs some attention for harsh conditions and staining.

- **Spray paint:** Turpentine or SPC 801
- **Permanent marker:** Methylated spirits or SPC 801

Never use any of the following on Compact Laminate:

- Do not use abrasive or polishing materials. Abrasive cleaners such as Jif Cream Cleanser, Ajax (powder or liquid), Chemco, Brasso, Mr. Muscle oven cleaner or Scrub free.
- Scourer pads, Wire wool or Sandpaper.
- High pressure water cleaning or steam cleaning of panels is not recommended.
- Neat Janola or other equivalent brands of bleaches.
- Any product containing strong mineral acid such as sulphuric acid, Battery acid, hydrochloric acid, nitric acid or phosphoric acid. Commercial toilet cleaners, grout removers, descalants, rust removers, etc.
- Care must be taken where cleaning agents or solvents are highly acidic or alkaline as these may permanently damage the surface.

Other Tips:

- The use of CRC or equivalent on hinges and indicator bolts is recommended at least once every 3 months (sooner for challenging environments).
- An occasional re-finish of the exposed edges with an “off the shelf” wood-polish will rejuvenate the original polished seen edges.
- Any chemicals should be washed off so that they don’t keep working on the panels.

See our Web site:

www.resco.co.nz/product/multicom - Cleaning instructions

For removal of graffiti – Please call our customer service team **0800 800 950**

IMPORTANT

Read before installation

- Walls must be straight and flush. When the battens are being installed ensure that walls are flush - this may require packing or planing.
- The moisture content of the timber framework should be less than 18%.
- Dry-fit every sheet before applying double-sided tape and MS Polymer.
- Wipe clean with activator, both the battens and also the MULTICOM[®] panel where the adhesive is being applied.
- 3mm expansion joints have been allowed for within the aluminium extrusions.
- Take care when applying MS Polymer not to let it spill onto the double-sided tape. This could cause the panel to move.
- Jointers should be screw fixed in place.
- Double sided tape must be used as it holds the panel in place until the adhesive cures.
- Ensure dust doesn't accumulate following application of the activator. This will prevent the adhesive from bonding with the panel.
- The moisture content of the Timber framework should be no more than 18%.

MultiCom[®] Wall panelling

Resco's MULTICOM[®] wall panelling system is a cost-effective, high-impact resistant one-panel system. Compact Laminate panels are blind fixed with no need for a conventional impact resistant backing sheet.

The system is Branz appraised for installation onto battens for wet areas (and flat walls) and directly fixed onto studs in dry areas.

2450 x 1850 Compact Laminate panels (6mm), can be fixed vertically or horizontally, and are attached to the wall using customised aluminium jointers with built-in expansion slots.

What tools are needed

Skill-saw:

Use a fine-tooth tungsten tipped blade.

Router:

Routers or tungsten tipped hole-saws can be used for cutting holes as needed.

Sausage Caulking or Cartridge Gun Knife

Screwdriver

Sandpaper:

No.400 sandpaper may be useful to eliminate sharp edges.

Suction cups for lifting panels.

If Timber frame: Staple Gun

If Concrete wall: Power Drill

Machining of MultiCom[®]

Use low feeds when using saws, drills and routers to ensure a clean cut.

Components required

Surface Activator

Holdfast double-sided foam Gator tape
12mm x 2mm x 30mtrs.

Jointers, Internal and External corners and End capping.

Holdfast 'Soudaseal' 240FC or
Holdfast 'Fixall' MS Polymer

Stainless Steel Screws

3.5mm drill bit

5mm Masonry bit

No.2 Pozi-Drive

(A) 8GA x 32 c/s screws

H3-Treated battens (or steel battens)

Vent strip

Building paper

8mm S/S staples

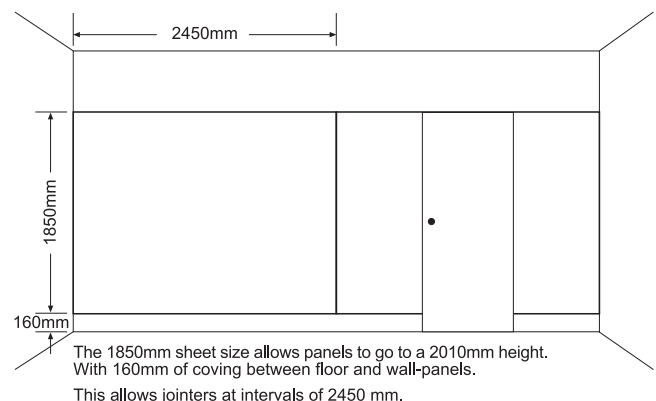
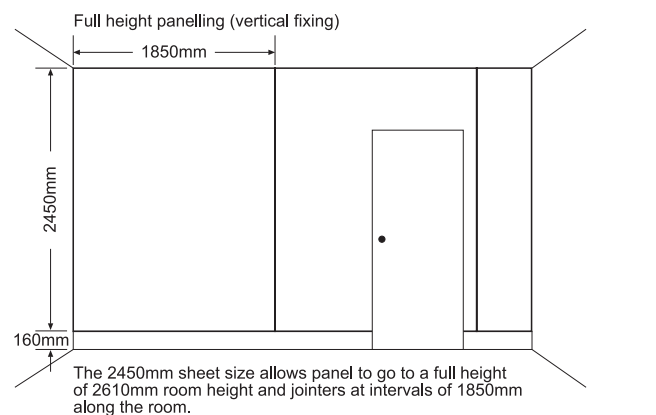

Jointers, Internal and External corners and End capping detail

INTERNAL CORNER 5063

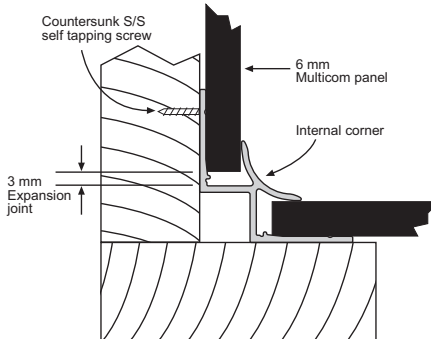

EXTERNAL CORNER 5064

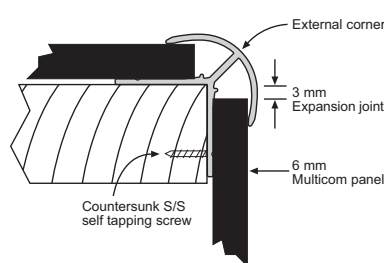

END CAPPING AL-1461

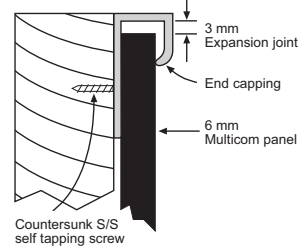

ANGLE RETURN X223

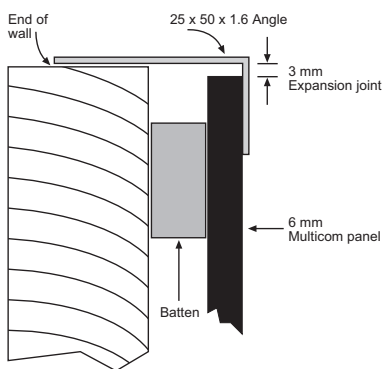

ANGLE RETURN 5510

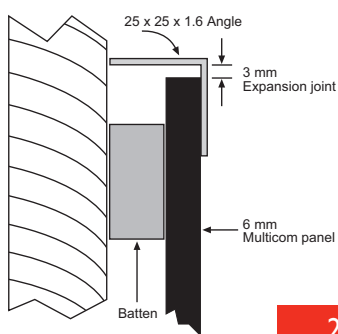

H JOINTER 4945

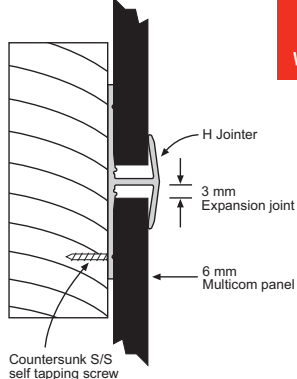

**2D-CAD
DRAWINGS
AVAILABLE**
Download at
www.resco.co.nz

Note: All diagrams are indicative only.

TYPICAL DETAIL FOR WET AREAS

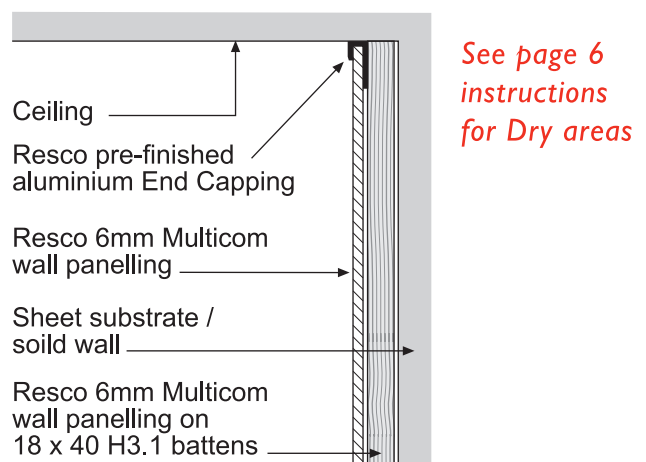

TYPICAL FLOOR UPSTAND DETAIL

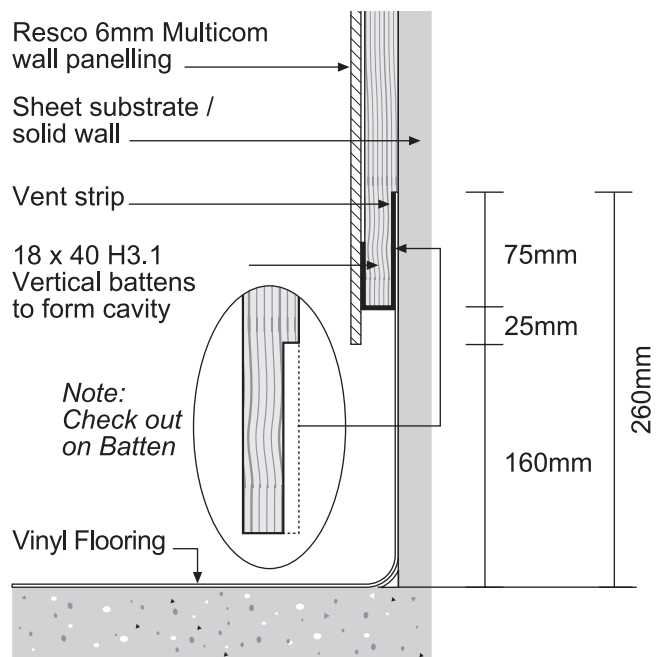

Timber framed walls Option 1. (Dry area)

Step 1

Fix a 200mm x 50mm nog at the base of the framing to provide backing for the vinyl.

Step 2

Floor vinyl to be laid and covered 250mm up the wall.

Step 3

Attach in place first Aluminium extrusion.

Use (A) 8GA x 32 screws.

Step 4

Dry fit each sheet to check it fits.

Note: The panels can be cut with a skill-saw using a fine-tooth Tungsten tipped blade and routers, or Tungsten tipped hole-saws can be used for cutting holes.

Step 5

Clean each stud with activator to ensure maximum adhesion. Apply Surface Activator with a clean cloth. By doing so the surface is cleaned, degreased and activated for the application of the MS Polymer.

Replace cloth regularly when dirty. Leave to evaporate till dry (2-5minutes).

Step 6

When dry, put a full height strip of double-sided tape on the side of each stud.

Step 7

Apply a 5mm bead of adhesive. Ensure it's no closer than 25mm from the edge of the tape, otherwise it could prevent the panel from sticking to the tape.

Step 8

Clean ALL surfaces of the panel that are in contact with MS Polymer with activator to ensure maximum adhesion. Apply Surface Activator with a clean cloth.

Replace the cloth regularly when dirty. Leave to evaporate till dry (2-5 minutes).

Step 9

Fit sheet – ensure flush and allow for 3mm expansion clearance between profiles and panel edges. Push panel on in place so that double-sided tape holds it in place until the adhesive cures.

Step 10

Insert the next Aluminium extrusion and continue.

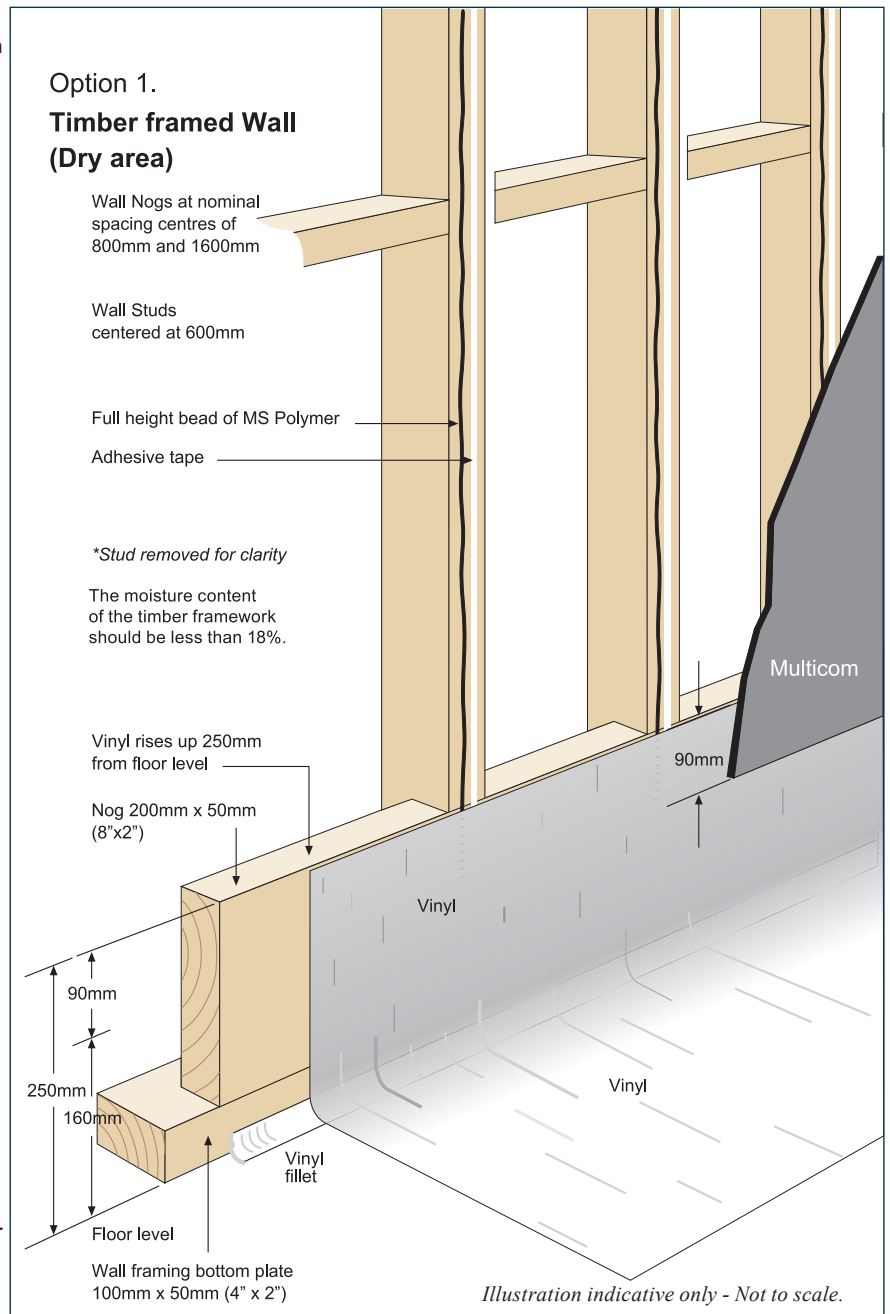

Timber framed walls Option 2. (Wet area)

Step 1

Fix a 200mm x 50mm nog at the base of the framing to provide backing for the vinyl.

Step 2

Floor vinyl to be laid and covered 260mm up the wall, then fix Vent Strip on to the wall at 185mm (bottom edge) from floor. **Use 8mm staples at 600 centres.**

Step 3

Fix building paper on studs ensuring that it overlaps with Vent strip.

Step 4

Using 18mm x 40mm H3.1 battens, attach battens vertically full height fix every 400mm, at 600 centres. **Use (A) 8GA x 32 screws with (F) plastic anchor if required).**

Walls must be straight and flush. When the battens are being installed ensure that walls are flush - this may require packing or planing. Ensure you check out the battens at the bottom, to allow for Vinyl and Vent strip.

Step 5

Attach in place first Aluminium extrusion.

Use (A) 8GA x 32 screws.

Step 6

Dry fit each sheet to check it fits.

Note: The panels can be cut with a skill-saw using a fine-tooth Tungsten tipped blade and Routers, or Tungsten tipped hole-saws can be used for cutting holes.

Step 7

Clean each batten with activator to ensure maximum adhesion. Apply Surface Activator with a clean cloth. By doing so the surface is cleaned, degreased and activated for the application of the MS Polymer. Replace cloth regularly when dirty. Leave to evaporate till dry (5 minutes).

Step 8

When dry, put a full height strip of double-sided tape on the side of each batten.

Step 9

Apply a 5mm bead of adhesive. Ensure it's no closer than 25mm from the edge of the tape, otherwise it could prevent the panel from sticking to the tape.

Step 10

Clean ALL surfaces of the panel that are in contact with MS Polymer with activator to ensure maximum adhesion. Apply Surface Activator with a clean cloth.

Replace the cloth regularly when dirty. Leave to evaporate till dry (5 minutes).

Step 11

Fit sheet – ensure flush and allow for 3mm expansion clearance between profiles and panel edges. Push panel on in place so that double-sided tape holds it in place until the adhesive cures.

Step 12

Insert the next Aluminium extrusion and continue.

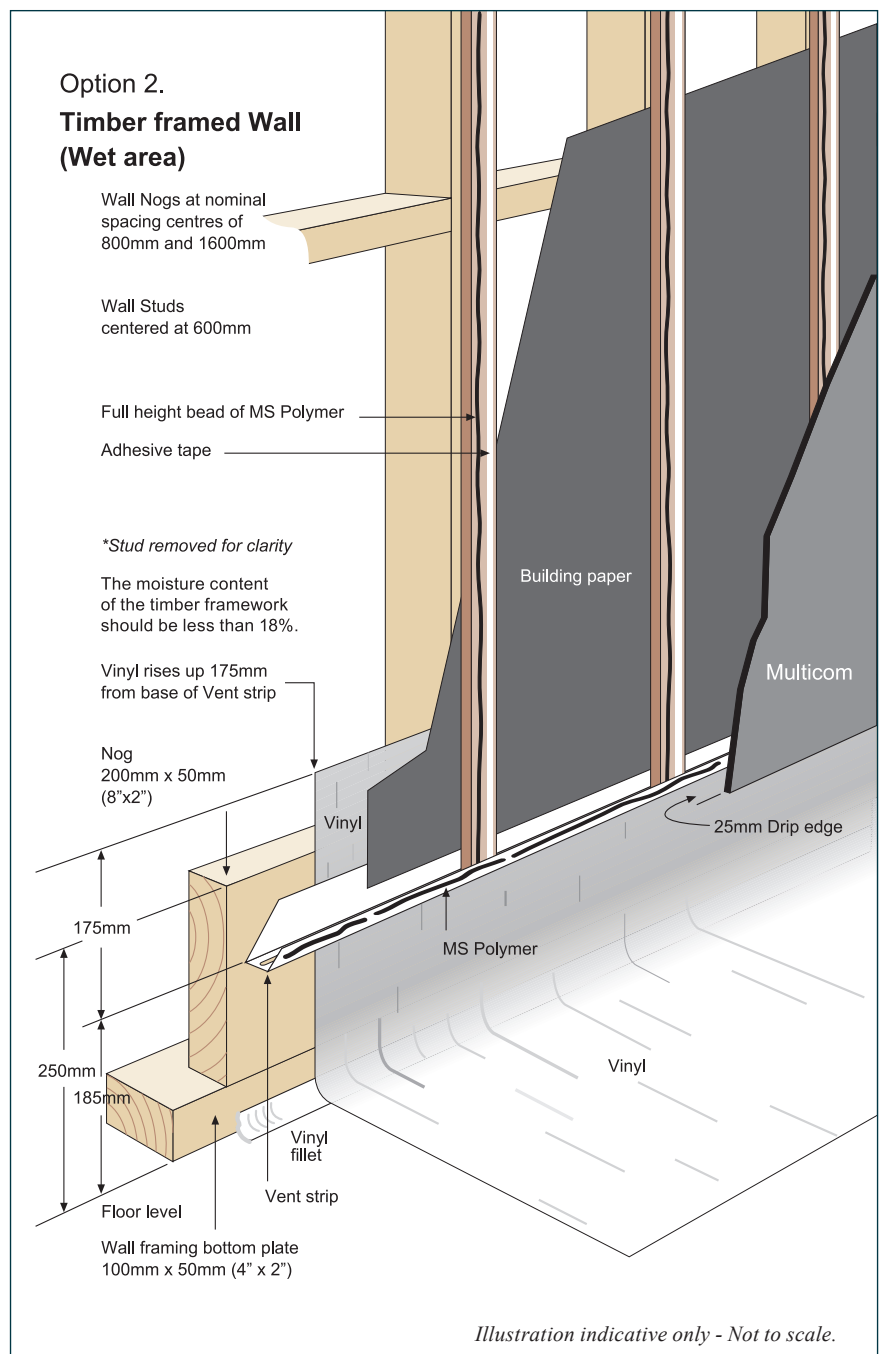

Solid flat surface walls Option 3. (Wet area)

Follow the numbered installation steps and detailed illustration references.

Flat surface walls like Concrete Block or Gib require battens to create an air gap behind the panels.

Step 1

Floor vinyl to be laid and coved 260mm up the wall, then fix Vent Strip on to the wall at 185mm (bottom edge) from floor. **Use (A) 8GA x 32 screws.**

Step 2

Using 18mm x 40mm H3.1 battens, attach battens vertically full height fix every 400mm, at 600 centres. **Use (A) 8GA x 32 screws with (F) plastic anchor if required.**

Walls must be straight and flush. When the battens are being installed ensure that walls are flush - this may require packing or planing. Ensure you check out the battens at the bottom, to allow for Vinyl and Vent strip.

- Concrete: Use either Countersunk Stainless Steel screws into rawl plugs, or shoot on with a shotfire gun.
- Gib: Find fixing (studs) and screw fix in place with Countersunk Stainless Steel screws, or nail on with 65mm-75mm Ring Shank nails.

Step 3

Attach in place first Aluminium extrusion. Secure with Countersunk Stainless Steel screws. **Use (A) 8GA x 32 screws.**

Step 4

Dry fit each sheet to check it fits. Note: The panels can be cut with a skill-saw using a fine-tooth Tungsten tipped blade and Routers, or Tungsten tipped hole-saws can be used for cutting holes.

Step 5

Clean each batten with activator to ensure maximum adhesion. Apply Surface Activator with a clean cloth. By doing so the surface is cleaned, degreased and activated for the application of the MS Polymer. Replace cloth regularly when dirty. Leave to evaporate till dry (5 minutes).

Step 6

When dry, put a full height strip of double-sided tape on the side of each batten.

Step 7

Apply a 5mm bead of adhesive. Ensure it's no closer than 25mm from the edge of the tape, otherwise it could prevent the panel from sticking to the tape.

Step 8

Clean ALL surfaces of the panel that are in contact with MS Polymer with activator to ensure maximum adhesion. Apply Surface Activator with a clean cloth. Replace the cloth regularly when dirty. Leave to evaporate till dry (5 minutes).

Step 9

Fit sheet – ensure flush and allow for 3mm expansion clearance between profiles and panel edges. Push panel on in place so that double-sided tape holds it in place until the adhesive cures.

Step 10

Insert the next Aluminium extrusion and continue.

