

Products: Vanities / Screens	Product Codes: RV and RS
Vanities and Screens: Updated May 2014	

Vanities and Screens

Vanities

Cost effective and easy to install, our pre-assembled units are ready for plumbers to connect.

Dirt traps have been minimised through innovative design, allowing for simple and efficient cleaning.

Suitable for high and low pressure water supply systems in high use ablution areas.

Screens

Resco's privacy screens are perfect for high use and wet areas.

We can do modesty screens up to full screens. The Compact Laminate panels provide extended product life, and the screen colour can be matched or contrasted to the cubicle systems and Multicom wall paneling.

Recommended for

Public areas

Schools

Sport and recreational areas

Community clubs

Camping and caravan sites, campgrounds

Shopping centres

Offices

Hotel complexes

Features

- Impervious to waters so suitable for high use and wet areas.
- Cost effective way to meet the building code
- Smooth screen surface for easy cleaning.
- CNC machined half round edging.
- Available in Resco AntiBac panels that kills bacteria for the lifetime of the panel
- New Zealand's largest range of Compact Laminate colour and finishes
- Custom made to suit
- Easy to clean and low maintenance

Edge treatment

- No edging is required as Compact Laminate is a finished product, a simple furniture oil enhances the black edge.



Options

Vanities

Different configurations are available, including corner, single, double or triple sinks.

Screens

- Full screens
- Modesty screens
- Kindy screens
- Shower screens

Colours

Panel Colours

Vanities and Screens are available in:

Resco AntiBac range
12 stock colours
20 accent colours –
(12 week lead time)

Laminex range
16 colours

Visit the Web site (www.resco.co.nz) or call for samples

See over page for typical system layout and sizing.

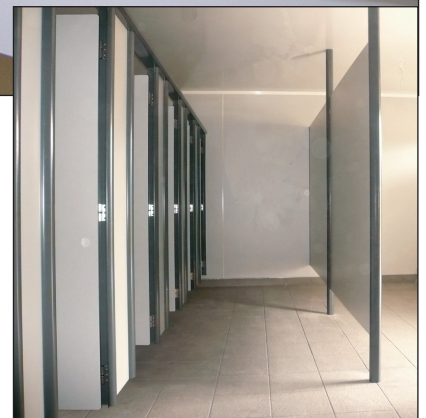

Aluminium colours

The Vanity and Screens aluminum extrusions are available in any of the Dulux - Duralloy powder coating colour range or Silver Anodised.

Our standard colour is Silver Pearl.

RESOCO ANTIBAC PANEL
Lifetime Protection

Vanities and Screens are now available in an exciting new Compact Laminate panel made with cutting-edge anti-microbial technology that continuously destroys bacteria, for the lifetime of the panel.

Vanities & Screens

Perfect for wet and high abuse areas

Dimensions

As vanities are custom made to your measurements, depths and widths, they can be varied to suit.

Standard vanity dimensions are:

- 1 Sink and mixer 900 mm wide x 500 mm deep x 250 mm high (plus 100 mm high splash screen)
- 2 Sinks and 2 mixers 1800 mm wide x 500 mm deep x 250 mm high (plus 100 mm high splash screen)
- 3 Sinks and 3 mixers 1800 mm wide x 500 mm deep x 250 mm high (plus 100 mm high splash screen)
- 6 Sinks and 6 mixers 3600 mm wide x 500 mm deep x 250 mm high (plus 100 mm high splash screen)

Durability and Maintenance

- Compact Laminate panels equal an extended life.
- Resco AntiBac panel kills bacteria for the lifetime of the panel.
- Being a tough, durable product it is perfect for high traffic locations and because it is impervious to water it is ideal in wet areas.
- Easily cleaned with a mild detergent.
- 10-year guarantee on panel integrity and 2 years on hardware



Lead time

If panel is in stock, once dimensions are confirmed, lead time can be as fast as a few days.

If accent colour range, this is ordered in and has a 12 week lead time.

Contact our team for accurate lead times.

Installation

Resco has an installation service available, or customers can install themselves as Resco vanities and screens can be delivered to site. Packs include installation manuals and hardware.

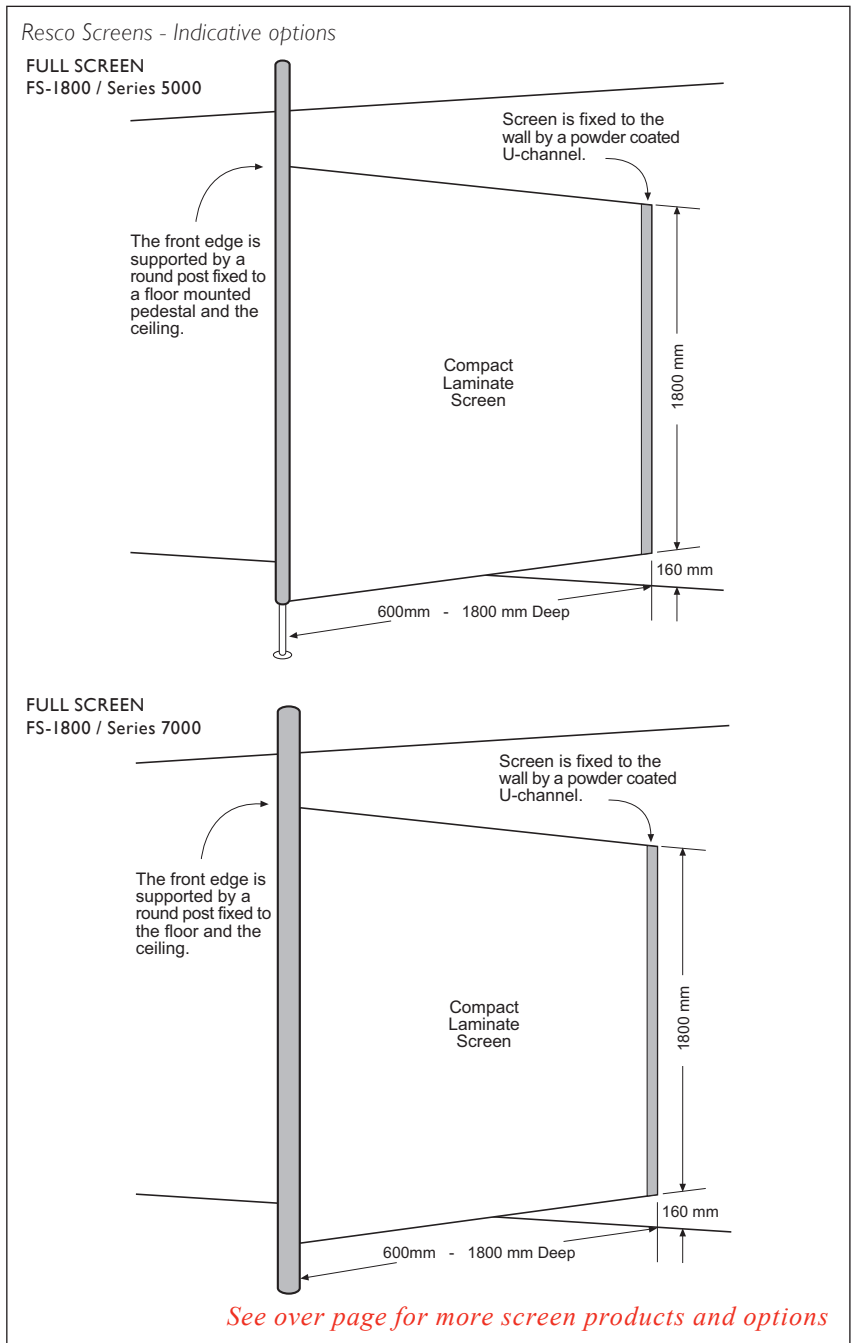
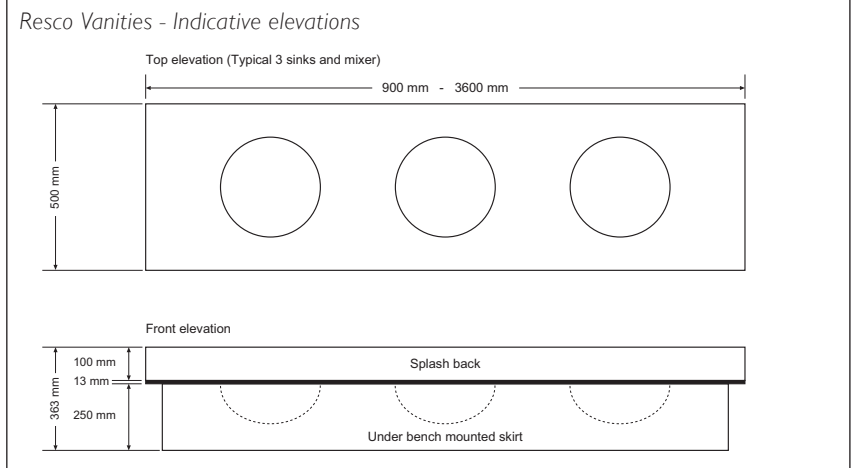

See over page for more screen products and options

This information may change without notice.

Vanities&Screens
Perfect for wet and high abuse areas

Resco shower screen - Indicative elevation

SHOWER SCREEN SC-1700

Shower screen can be either a Compact Laminate panel or curtain.

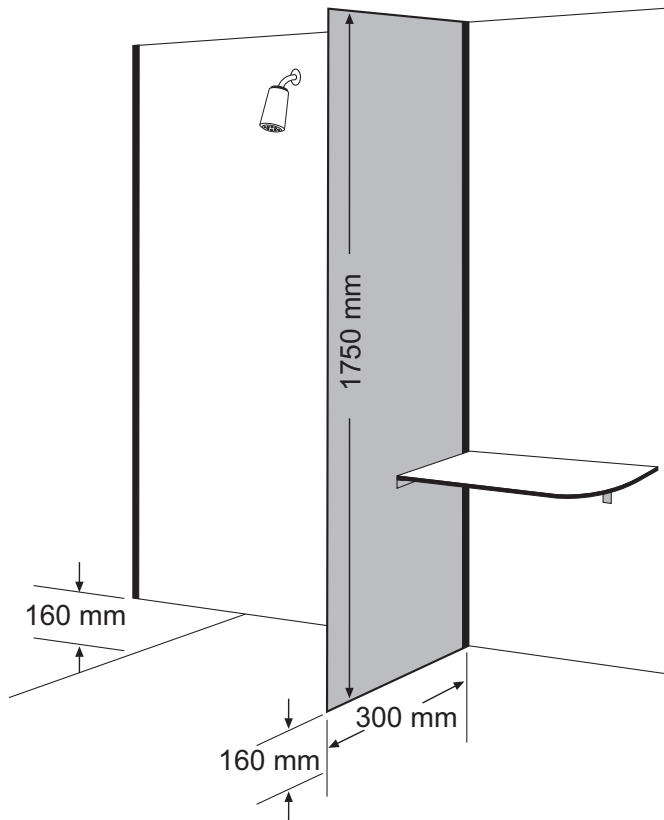

Resco screens - Indicative elevations

MODESTY SCREEN MS-900

Screen is fixed to the wall by a robust 75 mm half-rounded aluminium extrusion finished in satin anodising.

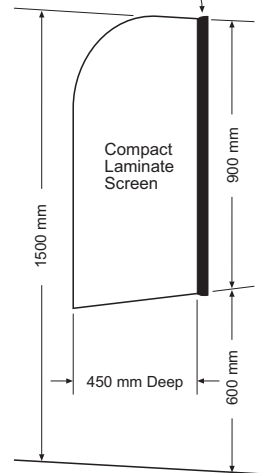

KINDY SCREEN KS-1200

Screen is fixed to the wall by a powder coated U-channel.

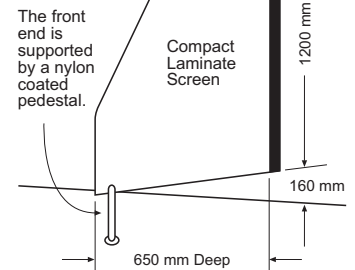

Resco shower seats - Indicative elevations

SHOWER SEAT SC-900p (shower panel option)

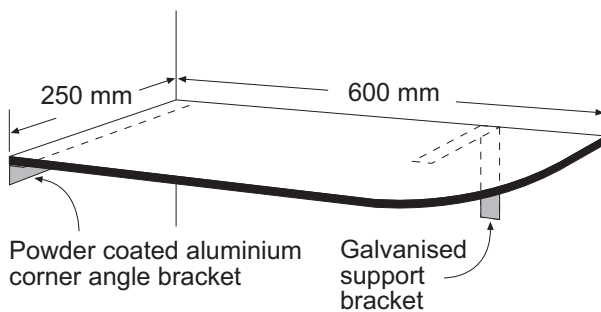

SHOWER SEAT SC-900c (shower curtain option)

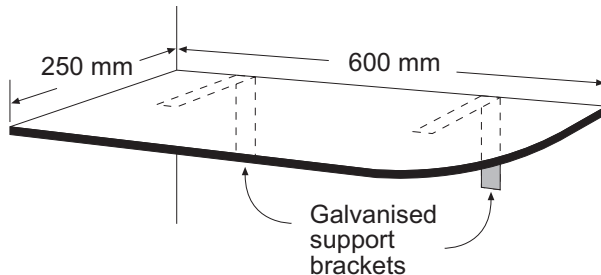

Contact

For pricing, email your plans or drawings to:

service@resco.co.nz
or fax **07 850 1026**.

Call Resco on **0800 800 950** for their full range or visit the Web site **www.resco.co.nz** and click on **Vanities/ Screens**.



Resco Limited.
12 Kahu Crescent
Te Rapa, Hamilton 3200
New Zealand

©Resco May 2014

This information may change without notice.

Vanities & Screens
Perfect for wet and high abuse areas